

Ion Technologies SHV40, 75 & 100

Sewage Ejector Pump

OPERATION MANUAL

Dated: 04/09/2018

Document Name: SHV40-75-100_OM

Page 1 of 8



SAFETY WARNINGS

Thank you for purchasing your Ion Technologies Pump. To help ensure years of trouble-free operation, please read the following manual carefully.



CAUTION: Read these safety warnings first before installing, servicing, or operating any pump.

Before Installation

This manual contains important information for the safe use of this product. Read this manual completely and follow the instructions carefully. Reasonable care and safe methods relating to the installation and operation of this product should be practiced. Check local codes and requirements before installation.



WARNING: Risk of Electrical Shock or Electrocutation. May result in serious injury or death or fire hazard. Installer must disconnect all electrical sources prior to installation, handling or servicing. Only qualified personnel may install this system. NFPA 70/National Electric Code (NEC) or local codes must be followed. System must be properly grounded according to NEC. Do not lift pump by power cord.



WARNING: Biohazard Risk. Once wastewater source has been connected to system,

biohazard risk exists. Installer(s) and/or service personnel must use proper Personal Protective Equipment and follow handling procedures per OSHA 29 CFR 1910.1030 when handling equipment after wastewater source has been connected to system.



WARNING: Risk of Asphyxiation. Installer(s) and/or service personnel must use proper Personal Protective Equipment and follow OSHA 29 CFR 1910.146 or OSHA 29 CFR 1926. Pump may be installed in a location classified by as a confined space.



WARNING: Risk of Fire or Explosion. Do not smoke or use open flames in or around this system. This system is not intended for use in hazardous locations per NFPA 70 National Electric Code. Do not pump flammable liquids. Consult factory for optional equipment rated for hazardous location use.



WARNING: Cutting Risk. Risk of serious cutting or amputation exists. Disconnect all power sources prior to servicing pump. Pump may start without warning.



CAUTION: Do not modify the cord and plug. When using the cord and plug, plug into a grounded outlet only. When wiring to a system control, connect the pump ground lead to the system ground.



CAUTION: Do not run the pump dry. Dry running can overheat the pump (causing burns to anyone handling it) and will void the warranty.



CAUTION: The pump normally runs hot. To avoid burns, allow it to cool for 30 minutes after shutdown before handling it.

Do not throw away or lose this manual. Keep it in a safe place so that you may refer to it often for the continued safe operation of the product.

OVERVIEW

These important instructions must be followed for satisfactory performance of your pump. Before installation, check your local electrical and plumbing codes. Be careful not to exceed the given specifications in the use of your pump.

Ion Technologies SHV40, 75 & 100

Sewage Ejector Pump

OPERATION MANUAL

Dated: 04/09/2018

Document Name: SHV40-75-100_OM

Page 2 of 8

Model	Motor Info.	Dis-charge	Solids Handling	GPM Rate @ 10 Ft Head	Maximum Head Rating	Maximum Flow Rating	Dimensions (Inches) (L x W x H)	Weight (Lbs)
SHV40M-11	1/2 HP 115/1, 8.5 FLA	2"	2"	70	0 GPM @ 25'	90 GPM @ 0'	9-1/8 x 5-1/2 x 16	31
SHV75M-11	3/4 HP 115/1, 11.5 FLA	2"	2"	93	0 GPM @ 28'	105 GPM @ 0'	10-1/2 x 6-1/2 x 18-1/2	41
SHV100M-11	1 HP 115/1, 14 FLA	2"	2"	128	0 GPM @ 32'	155 GPM @ 0'	10-1/2 x 6-1/2 x 18-1/2	41
SHV100M-21	1 HP, 208- 230/1, 7.7 - 7.0 FLA	2"	2"	128	0 GPM @ 32'	155 GPM @ 0'	10-1/2 x 6-1/2 x 18- 1/2	41

This pump series is suitable to pump water and also can be used both for permanent and temporary installation. The pump can be placed in a sump or sewage pit and is capable of passing 2" spherical solids.



WARNING: The pump can be used for sea water but not inflammable, corrosive, explosive or dangerous liquids. Make sure that the pump never runs without liquids.

INSTALLATION

Do not work on pump until power is unplugged. Do not cut off ground pin or use an adapter fitting. Do not use an extension cord.

The pump power cord should be connected to a separately fused, grounded line with a minimum capacity of 15 amps. It can be connected to non-fuse breaker as the recommended amperes. Never touch the pump when it is connected to electrical power.

1. Before installing or servicing this pump, be certain pump power source is disconnected.
2. Installation and electrical wiring must adhere to state and local codes and must be completed before priming pump. Check appropriate community agencies, or contact local electrical and pump professionals.

3. Call an electrician when in doubt. Pump should be connected to a separate 15 amp circuit breaker or 15 amp fuse block.

Note: That, plugging into existing outlets may cause low voltage at motor, causing blown fuses, tripping of motor overload, or burned out motor.

4. A permanent ground connection from pump to the grounding bar at the service panel is mandatory, Ion Technologies sump pumps come with a grounding conductor and a grounding-type attachment plug. Do not connect pump to a power supply until permanently grounded. For maximum safety, connect pump to a circuit equipped with a fault interrupter device when you position the pump's grounding wire.
5. Voltage of power supply must match the voltage of the pump.
6. Before installing pump, clear sump basin of any water, debris or sediment.



WARNING: Sump basin must be vented in accordance with local plumbing codes. Ion Technologies sump pumps are not designed for and can not be installed in locations classified as hazardous

7. The following may cause severe damage to pump and will void the warranty:
 - a. Using an extension cord.

- b. Cutting off the ground pin or using an adapter fitting.
- c. Working on pump or switch while plugged in.
- d. Removing motor housing, unscrewing impeller, or otherwise removing impeller seal
- e. Running the pump continuously.
- f. Pumping chemicals or corrosive liquids.
- g. Pumping gasoline or other flammable liquids.
- h. Piping, plastic PVC pipe could be installed in the outlet piping, but drain hose, galvanized steel or copper pipe may be used if desired. All piping must be clean and free of all foreign matter to prevent clogging. Use thread compound on all threaded joints unless specified otherwise. Be sure to seal the thread connection with tape when your using the pipe fitting to connect the flange.
- i. Pump will be inadequate if suspension liquids contain solid particles larger than 2" solids.

Electrical Wire Connection



WARNING: Verify that the voltage and frequency of the pump shown on the nameplate correspond to those available on the mains. The installer must make sure that the electric system is grounded in accordance with the law in force.

It is necessary to use cable with a length of 10' or 20' for outdoors. The plug and connections should be protected from water splashes. Before using the pump, always inspect it visually (especially power cable and plug).



CAUTION: Do not use the pump if it is damaged. If the pump is damaged, have it inspected by an authorized service center only.

Make sure that electric connections are protected from inundation. Protect the plug and the power cable from heat, oil or sharp edges.



CAUTION: Before servicing a pump, always shut off the main power breaker and then unplug the pump. Make sure you are not standing in water and are wearing insulated protective sole shoes, under flooded conditions, Contact your local electric company or a qualified licensed electrician for disconnecting electrical service prior to pump removal.



WARNING: The power cable must be replaced by qualified personnel only.

Grounding

The plug of the power cable has a double grounding contact, so that grounding can be performed by simply inserting the plug.

Overload Protection

This pump series has a built in thermal protection switch. The pump stops if an overload condition occurs. The motor restarts automatically after it has cooled down.

TROUBLESHOOTING

Pump does not run and hums

1. Line circuit breaker is off, or fuse is burned or loose.
2. Water level in sump has not reached turn-on level.
3. Pump cord is not making contact in receptacle and hums.
4. Float is stuck. It should operate freely in basin.
5. If all of the above are okay, then the motor could be malfunctioning.

Pump runs but does not deliver water

1. Check valve is installed backwards. Arrow on valve should point in direction of flow.
2. Discharge shut-off valve (if used) may be closed.
3. Impeller or volute openings are fully or partially clogged. Remove pump and clean.
4. Pump is air-locked. Start and stop several times by plugging and unplugging cord. Check

Ion Technologies SHV40, 75 & 100

Sewage Ejector Pump

OPERATION MANUAL

Dated: 04/09/2018

Document Name: SHV40-75-100_OM

Page 4 of 8

for clogged vent hole in pump case. Drill a 1/8" inch hole into PVC pipe.

5. Inlet hole in pump base is clogged. Remove pump and clean the opening.
6. Vertical pumping distance is too high. Reduce distance or change the discharge fittings of the pump.

Pump runs and pumps out sump but does not stop

1. Float is stuck in up position. Be sure float operates freely in basin.
2. Defective float switch, replace.
3. Defective vertical switch, replace.

Pump runs but delivers only a small amount of water

1. Pump is air-locked. Start and stop several times by plugging and unplugging cord. Check for clogged vent hole in pump case. Drill a 1/8" inch hole into PVC pipe.
2. Vertical pumping distance is too high. Reduce distance or change the discharge fitting of the pump.
3. Inlet hole in pump base is clogged. Remove pump and clean the opening.
4. Impeller or volute openings are fully or partially clogged. Remove pump and clean.
5. Pump impeller is partially clogged with tar or paint, causing motor to run slow and overload. Remove pump and clean.

Motor runs for a short time, then stops

1. Inlet hole in pump base is clogged. Remove pump and clean the opening.
2. Pump impeller is partially clogged with tar or paint, causing motor to run slow and overload. Remove pump and clean.
3. Motor stator may be defective.
4. Impeller or volute openings are fully or partially clogged. Remove pump and clean.

WARRANTY IS VOID IF...

1. Using an extension cord.
2. Power cord has been cut or the grounding prong removed or using an adapter fitting.
3. The switch has been disassembled or tampered with.
4. Any tags or labels have been removed.

Ion® Digital Level Control

Digital Level Control Switch

OPERATION MANUAL

Dated: 04/09/2018

Document Name: SHV40-75-100_OM

Page 5 of 8



Patent pending

FEATURES

1. First of its kind, solid-state sensing technology with no moving parts.
2. Space age design with no mechanical contact points.
3. Multipoint sealing mechanism that supersedes single surface seals.
4. Inverter rated for use with any battery back-up system.
5. Standard piggy back connection for use with any pump.
6. Suitable for sump and sewage applications.

PIPE MOUNTING BRACKET (OPTIONAL)

1. Determine bracket mounting position (Figure A).
2. Mount bracket to Ion® switch with screw already provided in Ion® switch (Figure B).
3. Mount Hose Clamp with switch around pipe at predetermined level. Cable should remain outside hose clamp (Figure C).
4. Tighten hose clamp.

Note: The Ion® switch is available in 6" or 8.5" ranges. A 10" range is available for special applications. See chart for available ranges and cord lengths. The range of the switch is the distance between the On and Off levels. The Off level is at the bracket mounting screw

of the switch. From this point, measure up either 6" or 8.5", depending on your switch's range, to find the On level. Please refer to the Installation Drawing.



CAUTION: Bottom of switch should not be mounted lower than suction inlet of pump. When installing the Ion® switch with the pipe mounted bracket be sure not to set the switch too low or too high on the pipe. The Ion® must be installed above the inlet of the pump to prevent air-locking as shown in the installation drawing.

To prevent flooding do not set the on point of the switch higher than the top of the basin.

Model	Cord	Range
IN-006-010-10PA-B	10	6
IN-085-010-10PA-B	10	8.5
IN-006-020-10PA-B	20	6
IN-085-020-10PA-B	20	8.5

PIGGY-BACK INSTALLATION

Electrical outlet must not be located in pump pit.

Electrical outlet voltage, piggy-back plug voltage and pump voltage must all be the same voltage.

DO NOT CUT plug off unit.

Ensure vent tube on plug is protected from moisture, dirt and insects and other items that could plug or block tube.

1. Insert the Ion® switch's piggy-back plug into the outlet.
2. Plug pump into piggy-back plug as (Figure E).
3. Allow system to cycle to ensure proper installation.

Please note this product may not work in conjunction with other controllers.

Note: The Ion® switch does not operate like a standard pressure switch. There are no contacts to wear out, so when pressure is applied, there will not be a click.

Ion® Digital Level Control

Digital Level Control Switch

OPERATION MANUAL

Dated: 04/09/2018

Document Name: SHV40-75-100_OM

Page 6 of 8

SAFETY PRECAUTIONS



CAUTION: To prevent electric shock, ensure product is connected to a grounded outlet. The electrical outlet should be properly wired to a dedicated 15A circuit breaker. Proper short-circuit and overload protection must be provided at the distribution panel. Install in accordance with all local and national electrical codes.



WARNING: Electrical outlet must not be located in pump pit. For best performance, do not use electrical extension cords.

INSTALLATION DRAWING

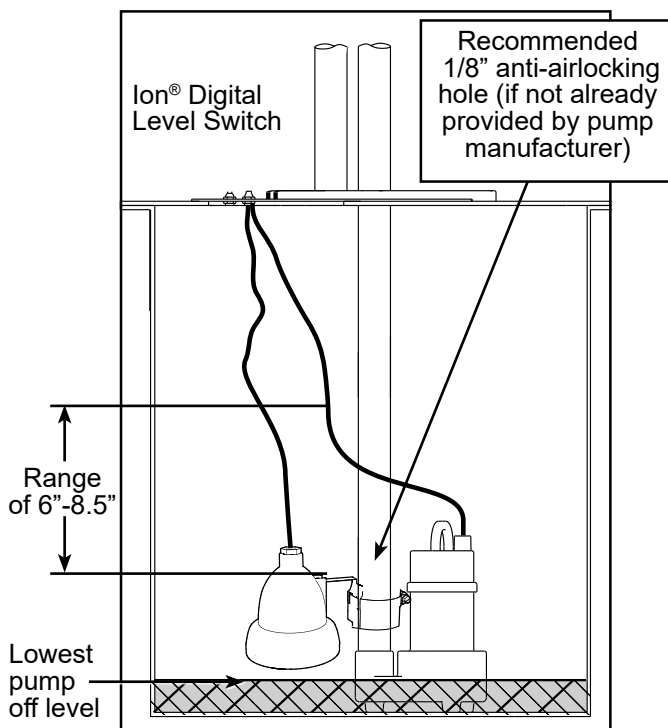

BE SURE TO MOUNT THE ION SWITCH AT PROPER LEVEL.

FIGURE A

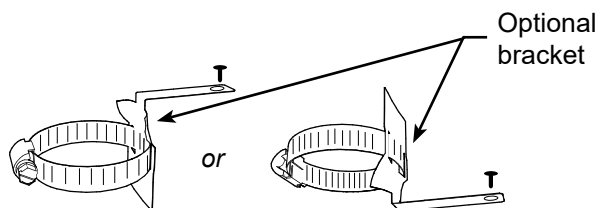

FIGURE B

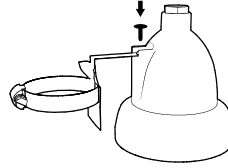

FIGURE C

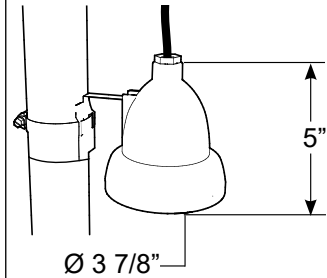
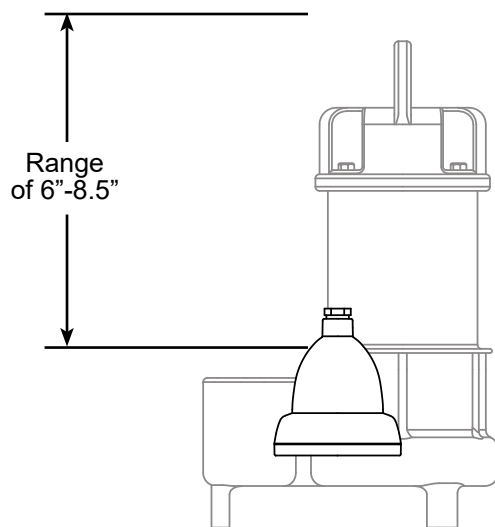
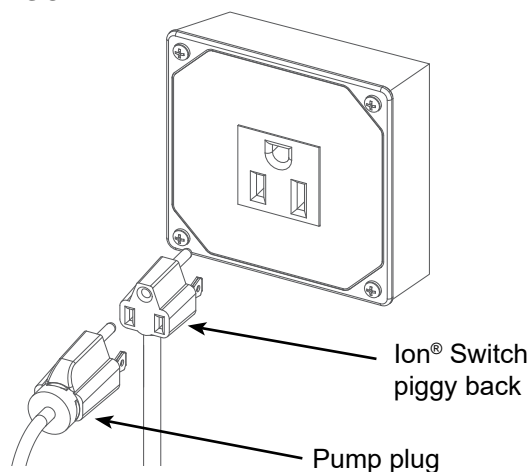

FIGURE D



NOTE: If you purchased a pump with the Ion switch hard-mounted to the pump (**Figure D**) and the installation requires the switch be mounted to the pipe, the pipe-mount bracket is sold separately, PN: IN-SPB1-1.

FIGURE E



TROUBLESHOOTING**Switch Does Not Turn On Pump**

1. Test the pump without the Ion® switch
 - a. Plug the pump directly into the wall outlet, without plugging it into the switch plug.
 - b. If pump still does not run, see the troubleshooting section in the pump manual.
 - c. If the pump does run, continue to the next step.
2. Test the switch with the pump
 - a. Plug the pump into the Ion® switch and plugging the Ion switch plug into the wall.
 - b. Push up on the sensing plate through the center hole on the underside of the switch. Note that, being an electronic switch, you will not hear a clicking sound.
 - c. If the pump does not turn on, the switch will have to be replaced.
 - d. If the pump does turn on, continue to the next step.
3. Verify the range of the switch
 - a. The part number can be found on the switch cord tag.
 - i. IN-006... = 6" range
 - ii. IN-085... = 8.5" range
 - iii. IN-010... = 10" range (for special applications)
 - b. For a pipe-mounted switch, see Page 2, Installation Drawing to verify that the On level is appropriate for your basin.
 - i. Lower the switch on the pipe so the On level is at a point within the basin, insuring that the Off level does not fall below the minimum level shown in the Installation Drawing.

- ii. If the On level is still too high, the switch will have to be replaced with a lower range Ion® switch.
 - c. For a pump-mounted switch, see Page 2, Figure D to verify that the On level is appropriate for your basin.
 - i. If the On level is too high, the switch will have to be replaced with a lower range Ion switch.

Switch Does Not Turn Off Pump

1. Unplug the pump from the Ion® plug and then unplug the Ion plug from the wall outlet.
2. Plug the pump back into the Ion® plug and plug the Ion plug back into the wall outlet.
 - a. If the pump does not turn on right away, and the water level is not at the On level, let the pump go through an On / Off cycle a few times to insure that the switch is functioning properly. The basin may need to be filled with a garden hose or bucket.
 - b. If the pump turns on right away, and the water level is not at the On level, the switch will have to be replaced.

WARRANTY IS VOID IF...

1. Using an extension cord.
2. Power cord has been cut or the grounding prong removed or using an adapter fitting.
3. The switch has been disassembled or tampered with.
4. Any tags or labels have been removed.
5. Used in a heavy grease application
6. Used in applications exceeding the designed temperature range of 32 - 104 degrees F.

3 Year Residential Warranty

1. **Coverage and Term.** Metropolitan Industries, Inc. (“**Metropolitan**”) warrants to the original purchaser (the “Buyer”) of each Ion|StormPro product (the “product”), that any part thereof which proves to be defective in material or workmanship within three (3) years from date of manufacture, will be replaced at no charge with a new or remanufactured part, F.O.B. factory. Buyer shall be responsible for all freight charges and all costs of field labor or other charges incurred in the removal and/or reinstallation of any product, part or component thereof.
2. **Exclusions. THE WARRANTY IS SUBJECT TO THE FOLLOWING CONDITIONS AND EXCLUSIONS:**
 - (a) The Warranty excludes products or workmanship which becomes defective as a result of: (i) earthquake, fire, storms, the elements or any other acts of God; (ii) normal wear and tear from use; (iii) accident, misuse, abuse or neglect; (iv) modifications made by Buyer or any third party, other than **Metropolitan**; and (v) Buyer’s failure to properly install, maintain, service and/or operate the product under normal conditions and according to manufacturer’s instructions.
 - (b) **Metropolitan** shall not be responsible for, and the Warranty shall not cover, extended damage which occurs because of Buyer’s failure to notify **Metropolitan** promptly in writing of apparent defects.
 - (c) Any part or component designated as manufactured by anyone other than **Metropolitan** shall be covered only by the express warranty of the manufacturer thereof.
 - (d) The Warranty shall lapse upon Buyer’s failure to fully comply with the terms and conditions of its contract with **Metropolitan**, including Buyer’s failure to pay the purchase price for the product or any portion thereof. Buyer’s subsequent compliance with the terms and conditions of any such contract, will not cause the term of the Warranty to extend beyond the time period set forth above.
 - (e) No actions taken by **Metropolitan** to correct a defect in a product shall extend the Warranty beyond the period set forth above. **Metropolitan** shall not be obligated to remedy any defect, where otherwise required pursuant to the Warranty unless and until Buyer notifies **Metropolitan** in writing of the defect and then only if such notification is made prior to the expiration of the period set forth above.
3. **Process of Claims and Repairs.** **Metropolitan** agrees that if the product or any part or component thereof shall fail to conform to the terms of this Warranty, **Metropolitan** shall replace such nonconforming product, part or component at the original point of delivery and furnish instruction for its disposition. Any transportation charges involved in such disposition and all costs of field labor or other charges incurred in the removal and/or reinstallation of any product, part or component thereof shall be the responsibility of Buyer.
4. **Limitation on Liability.** Notwithstanding any provision to the contrary, **Metropolitan’s** entire liability under this Warranty shall not in the aggregate exceed, and Buyer’s exclusive and sole remedies are, to the extent permitted by law, shall be to secure replacement of the defective product. **UNDER NO CIRCUMSTANCES SHALL METROPOLITAN BE LIABLE UNDER THE WARRANTY FOR ANY INDIRECT, PUNITIVE, SPECIAL, EXEMPLARY, CONSEQUENTIAL OR INCIDENTAL DAMAGES (INCLUDING LOST PROFITS, REVENUE, USE OR ECONOMIC ADVANTAGE).**
5. **Express Waiver of Any Other Warranties. THE EXPRESS WARRANTY SET FORTH IN THIS WRITTEN WARRANTY IS THE ONLY WARRANTY MADE BY METROPOLITAN, OR ANY OTHER PARTY, IN CONNECTION WITH ANY PRODUCT PURCHASED FROM METROPOLITAN. NEITHER METROPOLITAN, NOR ANY OTHER PARTY, MAKES ANY OTHER EXPRESS OR IMPLIED WARRANTY WHICH IS NOT SET FORTH HEREIN, AND METROPOLITAN HEREBY DISCLAIMS AND BUYER HEREBY WAIVES ALL IMPLIED WARRANTIES, INCLUDING THE IMPLIED WARRANTY OF MERCHANTABILITY AND THE IMPLIED WARRANTY OF FITNESS FOR A PARTICULAR PURPOSE.**
6. **Not Transferable.** The Warranty may not be transferred and shall be void on the sale or other transfer of the product.
7. **Products and Warranty Subject to Change.** **Metropolitan** reserves the right to make revisions to its products and their specifications, and to revise this Warranty and related information without notice.